



## Overview

A world-class SNMP & LDAP compatible SSL-protected Access Control Time Attendance Linux web-based Biometrics & RFID, Smartcard & PIN System. With all software and hardware built-in to the system, ACTAtek can be used in a standalone mode without the need of costly & complex dedicated architecture.

Network support from the reliable TCP/IP networking protocol allows ACTAtek to be operated in a multiple device environment in primary & secondary mode enhancing its functionalities. Moreover, its modular build and cross-platform SOAP-based API allows ACTAtek to be integrated with any IT / Secure Access software & hardware systems.

## Models Available

### PIN Model



### Smartcard Model



### Fingerprint Model



### Combination Model



CMOS CAMERA OPTIONAL ON ALL MODELS

## Demo Case



To be more easier to demonstrate the functionalities and capabilities of ACTAtek, ACTAtek offers the demo case with all necessary hardware connected. All you need to do is to connect the AC plug and a LAN cable.

## Accessories



## Optional Software



## Access Control & Time Attendance

### CLIENT LIST

1. Educational
2. Health Care
3. Commercial
4. Day Care Centers
5. Banking
6. Government
7. Residential

### RESOURCES

Brochures, Manuals, Quick Installation, Network Diagrams, Etc

### CONTACT:

**Canada**  
ACTAtek Technology Inc  
Suite 200, 10801 Sheldridge Way  
Richmond, BC V6X 2W8  
Canada  
Phone: 604 278 6888  
Fax: 604 278 6082  
Support Hotline: 208 201 2346  
E-mail: sales-ca@actatek.com

**Hong Kong**  
ACTAtek Pte Ltd  
1101-1103, 11/F, Yardley Comm. Bldg  
3 Connaught Road West  
Sheung Wan, Hong Kong  
Phone: 852 2319 1333  
Fax: 852 2778 8997  
Support Hotline: 852 2153 1131  
E-mail: sales-row@actatek.com

**UK**  
ACTAtek UK Ltd  
Unit 7 Lightning way,  
West Heath, Birmingham B31 3PH  
U.K.  
Phone: 44 121 411 2288  
Fax: 44 121 411 2299  
Sales Tel: 44 121 288 9923  
E-mail: sales-EU@actatek.com

**Singapore**  
ACTAtek Pte Ltd  
18 Boon Lay Way  
#09-96/97/98 TradeHub 21 609966  
Singapore  
Phone: 65 65154520  
Fax: 65 65154521  
E-mail: sales-asian@actatek.com



Manufacturer of award-winning web-based biometric device since 2001

## Access Control / Time Attendance

### ACCESS CONTROL

- Protect of valuables
  - Instant Email/SMS Notification
  - Disaster I.D. management
- ### TIME ATTENDANCE
- No buddy punching
  - Barber law compliance

### MODELS

CMOS CAMERA OPTIONAL ON ALL DEVICES



CMOS Camera

Company Name

Time

Trigger Type

Key Pad Module

Previous

Finger Print Sensor

Date

Door Bell

Menu

Back

Enter Delete

Next

Certifications:  
FCC, CE, IP 65  
UL

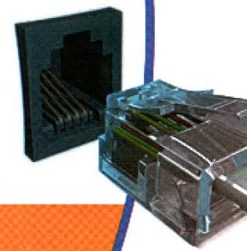



## Specification

## Internal Structure and connections

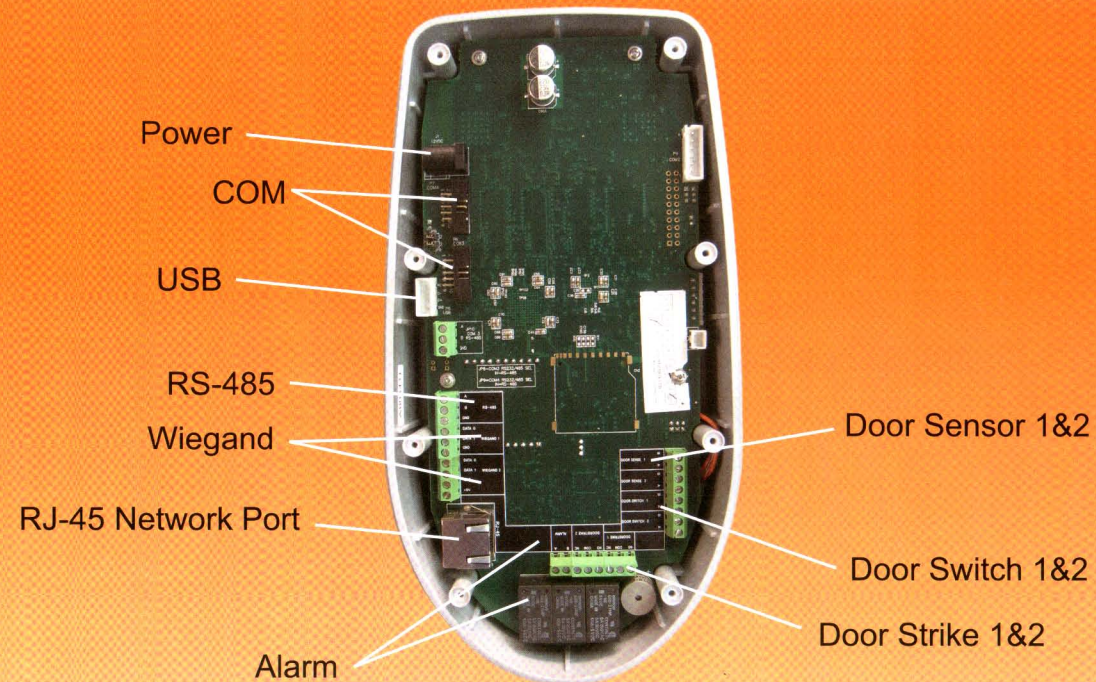
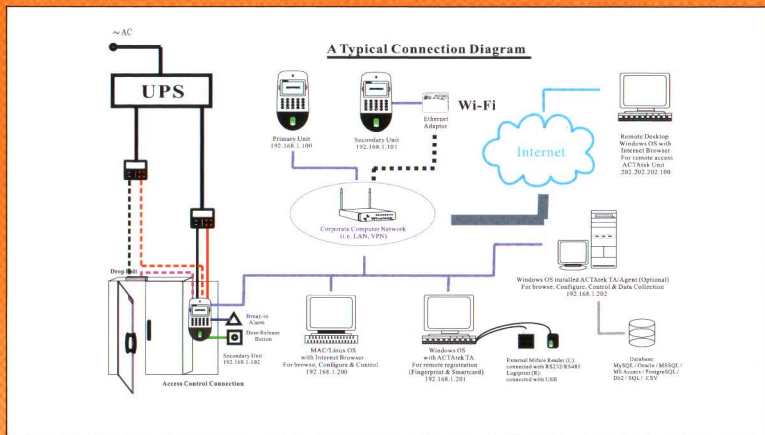

### Standard Features

Model:	Keycard + CMOS camera	Fingerprint + Smartcard	Smartcard	Fingerprint only
Fingerprint enrollment	✓	✗	✓	✗
Built-in smartcard reader	✗	✓	✓	✗
Built-in web and database server	✓	✓	✓	✓
Number of users	1x/3x/5x 10x/15x/20x	1x/3x/5x 10x/15x/20x	1x/3x/5x 10x/15x/20x	1x/3x/5x 10x/15x/20x
Max. transaction records stored	75000 log for 1k, 3k, 5k user model 10000 log for 10k, 15k, 20k, 30k user model			
Exchange information between devices (Primary / Secondary)	✓	✓	✓	✓
Static IP address assignment	✓	✓	✓	✓
Dynamic IP address assignment	✓	✓	✓	✓
Dimension of LCD (inches x inches)	✓	✓	✓	✓
Non-volatile memory	128/256MB			
Computer supported (with internet browser)	Mac OS Windows 95/98/NT/2000/XP/Vista			
Valid Characters for employee ID	0-9, A-C (max. 16 characters)			
Authentication time	< 1 second			

Distributed by:

Model:	Keycard + CMOS camera	Fingerprint + Smartcard	Smartcard only	Fingerprint only
Database interface support	ODBC / JDBC			
Encryption	Secure Socket Layer			
Multilingual support	✓	✓	✓	✓
Network interface	10BT Ethernet (Built-in) GSM/GPRS, Wi-Fi, Modem			
Expansion	RS-232/RS-485 Wiegand			
Operation mode	Primary/Secondary mode			
Programming API	SOAP API			
Report	✓	✓	✓	✓
Remote Control	✓	✓	✓	✓
Operation temperature	-20°C to 60°C			
Modules	CPU/Fingerprint Mifare / Legic HID Proximity HID/Class / FeliCa EM / Contact card LCD & Keypad CMOS Camera	RFID Card 13.56MHz ISO 14443A/B and 15693 125kHz		
Modes of Authentication	Fingerprint, Smartcard, PIN ID + Fingerprint Smartcard + Fingerprint Smartcard + PIN			
Mobile	Optional mobile battery			
Relay support	2 relays			
Case	IP65 – fluid ingress, dust, salt, fog protection			
Safety standard	CE, FCC, IP65			
Software standard	SNMP Compliant LDAP Compliant (Available on certain models)			

## ACTatek Accessories

### External Mifare Reader

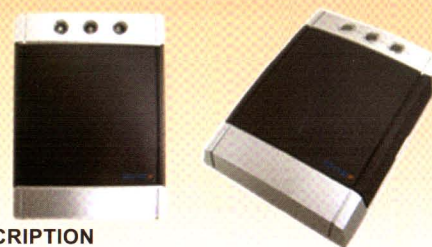

#### DESCRIPTION

The External Mifare Reader is a highly economical option, especially when it is critical to track both IN and OUT data of your employees without the need of 2 complete ACTatek units installed at both sides of the doors

### Secure External Relay



#### DESCRIPTION

The Secure External Relay provides an extra layer of security when an ACTatek is installed outdoors (of either a office building or a residential area). With the external relay, you can now install an ACTatek outdoors without having to worry about the connection being tipped or wires crossed by intruders! This increases security in your office/residential premises without expensive monitoring devices